

TPS852

- Mobile Phones
- Notebook PCs, PDAs
- Video cameras, Digital Still Cameras
- Other Equipment Requiring Luminosity Adjustment

The TPS852 is an ultra-compact surface-mount photo-IC for illuminance sensors which incorporates a photodiode and current amp circuit in a single chip.

The sensitivity is superior to that of a phototransistor, and exhibits little variation.

It has spectral sensitivity closer to luminous efficiency and excellent output linearity.

With its ultra-compact surface-mount package, this photo-IC can be used as the power-saving control for domestic appliances or for backlighting for displays in cellular phones, this device enables low power consumption to be achieved.

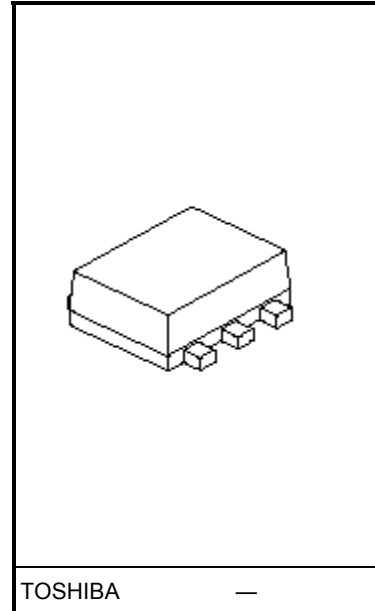

Weight: 0.003 g (typ.)

- Ultra-compact and light surface-mount package suitable for lead-free soldering and reflow soldering: $1.6 \times 1.6 \times 0.55$ mm
- Excellent output linearity of illuminance
- Little fluctuation in light current and high level of sensitivity
 - : $I_L = 40 \mu\text{A}$ (typ.) @ $E_V = 100$ lx using fluorescent light
 - : Light current variation width: $\times 1.67$
 - (when light current classification is specified.)
 - : Little temperature fluctuation
- Built-in luminous-efficiency correction function, reduced sensitivity variations due to various light sources
 - : I_L (using incandescent light)/ I_L (using fluorescent light) = 1.2 (typ.)
- Low supply voltage, making device suitable for battery-powered equipment: $V_{CC} = 2.7$ V to 5.5 V

Maximum Ratings (Ta = 25°C)

Characteristics	Symbol	Rating	Unit
Supply voltage	V_{CC}	-0.5 to 7	V
Output voltage	V_{OUT}	$\leq V_{CC}$	V
Light current	I_L	5	mA
Permissible power dissipation	P	35	mW
Power dissipation derating (Ta > 25°C)	$\Delta P/^\circ\text{C}$	-0.5	mW/°C
Operating temperature range	T_{opr}	-30 to 85	°C
Storage temperature range	T_{stg}	-40 to 100	°C
Soldering temperature range (Note 1)	T_{sol}	260	°C

Note 1: The reflow time and the recommended temperature profile are shown in the section entitled Handling Precautions.

Electrical and Optical Characteristics (Ta = 25°C)

Characteristics		Symbol	Test Condition	Min	Typ.	Max	Unit
Supply voltage		V_{CC}	Ta=25°C	2.7	—	5.5	V
Supply current		I_{CC}	$V_{CC} = 3\text{ V}$, $E_V = 1000\text{ lx}$ $R_L = 1\text{ k}\Omega$ (Note 2)	—	480	950	μA
Light current (1)		$I_L (1)$	$V_{CC} = 3\text{ V}$, $E_V = 100\text{ lx}$ (Note 2), (Note 4)	—	48	91.8	μA
Light current (2)		$I_L (2)$	$V_{CC} = 3\text{ V}$, $E_V = 10\text{ lx}$ (Note 3), (Note 4)	2.7	4.0	5.4	μA
Light current (3)		$I_L (3)$	$V_{CC} = 3\text{ V}$, $E_V = 100\text{ lx}$ (Note 3), (Note 4)	27	40	54	μA
Light current ratio		$\frac{I_L (1)}{I_L (3)}$	—	—	1.2	1.7	
Dark current		I_{LEAK}	$V_{CC} = 3.3\text{ V}$, $E_V = 0$	—	—	0.1	μA
Saturation output voltage		V_O	$V_{CC} = 3\text{ V}$, $R_L = 150\text{ k}\Omega$, $E_V = 100\text{ lx}$ (Note 3)	2.2	2.35	—	V
Peak sensitivity wavelength		λ_p	—	—	600	—	nm
Switching time	Rise time	t_r	$V_{CC} = 3\text{ V}$, $R_L = 5\text{ k}\Omega$ (Note 5)	—	11	1000	μs
	Fall time	t_f		—	400	2000	
	Delay time	t_d		—	250	—	
	Storage time	t_s		—	35	—	

Note 2: CIE standard A light source is used (color temperature = 2856K, approximated incandescence light).

Note 3: Fluorescence light is used as light source. However, white LED is substituted in a mass-production process.
 I_L classification $I_L (3) \rightarrow A: 30\ \mu\text{A}$ to $50\ \mu\text{A}$

Note 4: Light current measurement circuit

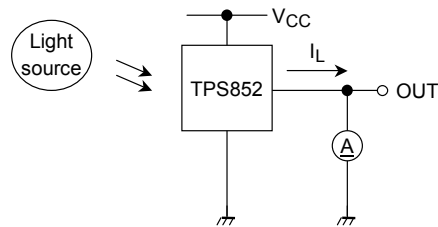

Note 5: Switching time measurement method

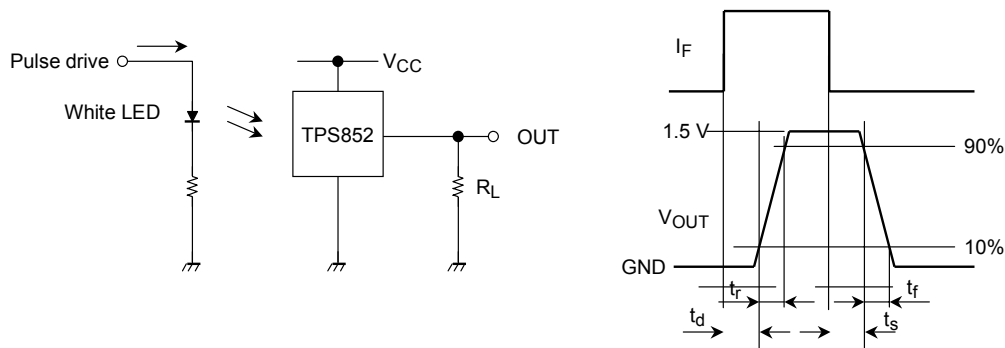

Package Dimensions

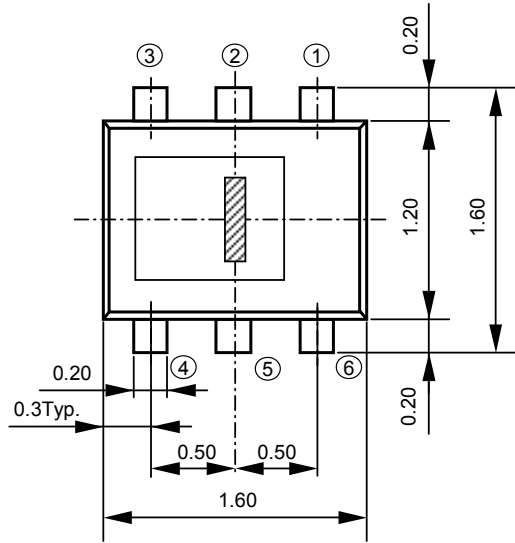

Unit: mm
 Tolerance: ± 0.1
 (): Reference value

: Light-receiving area

Size of light-receiving area:
 (0.51mm x 0.12mm)

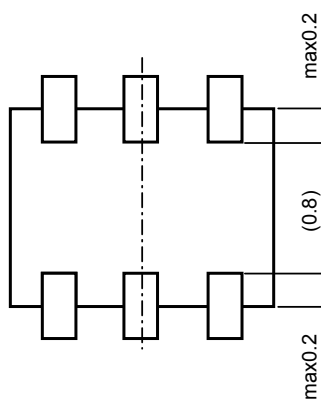
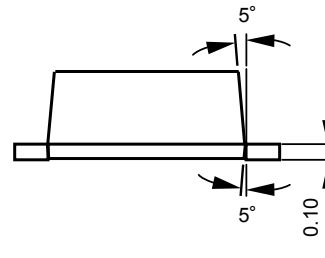
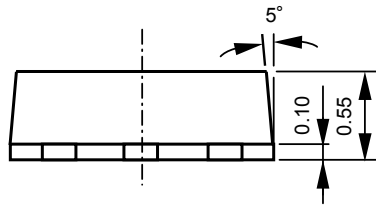

Pin connection

1. V_{CC}
2. GND
3. GND
4. GND
5. GND
6. OUT

Weight: 0.003 g (typ.)

Block Diagram

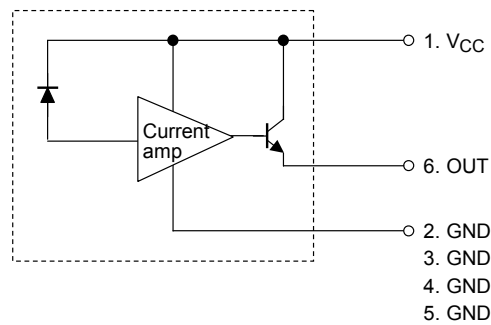

Handling Precautions

When Vcc is turned on it takes at least 200 ms for the internal circuit to stabilize. During this time the output signal is unstable. Please do not use the unstable signal as the output signal.

Moisture-Proof Packing

- (1) To avoid moisture absorption by the resin, the product is packed in an aluminum envelope with silica gel.
- (2) Since the optical characteristics of the device can be affected during soldering by vaporization resulting from prior absorption of moisture and they should therefore be stored under the following conditions:
Temperature: 5°C to 30°C, Relative humidity: 60% (max), Time: 168 h (max)
- (3) Baking in taping with reel is required if the devices have been store unopened for more than six months or if the aluminum envelope has been opened for more than 168 h.
These devices are packed on tapes; hence, please avoid baking at high temperature.
Recommended baking conditions: 60°C for 12 h or longer, Perform baking only once

Mounting Precautions

- (1) Do not apply stress to the resin at high temperature.
- (2) The resin part is easily scratched, so avoid friction with hard materials.
- (3) When installing the assembly board in equipment, ensure that this product does not come into contact with other components.

Mounting Methods

- (1) Reflow soldering
 - Package surface temperature: 260°C (max)
 - Please perform reflow soldering using the following reference temperature profile.
Perform reflow soldering no more than twice.

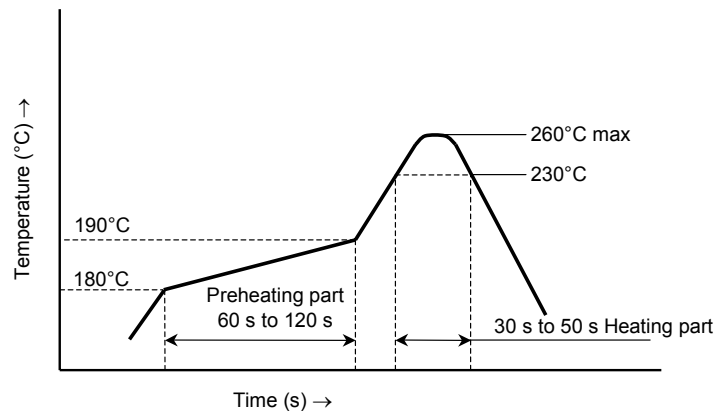

- Please perform the first reflow soldering within 168 h after opening the package with reference to the above temperature profile.
- Second reflow soldering
In case of second reflow soldering, it should be performed within 168 h after first reflow under the above conditions.
Storage conditions before second reflow soldering: 30°C, 70% RH or lower
- Do not perform flow soldering.
- Make any necessary soldering correction manually.
(do not do this more than once for any given pin.)
Temperature: no more than 350°C (25 W for soldering iron)
Time: within 5 s

(2) Recommended soldering pattern

Unit: mm

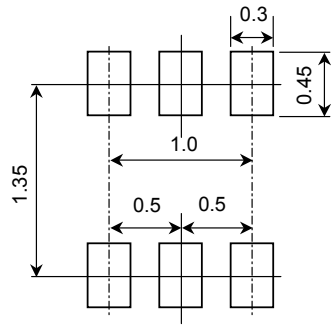

(3) Cleaning conditions

When cleaning is required after soldering

Chemicals: AK225 alcohol

Temperature and time: 50°C × 30 s or 30°C × 3 mins

Ultrasonic cleaning: 300 W or less

Packing Specification

(1) Packing quantity

Reel (minimum packing quantity)	3,000 devices
Carton	5 reels (15,000 devices)

(2) Packing format

An aluminum envelope containing silica gel and reels is deaerated and sealed.

Pack shock-absorbent materials around the aluminum envelopes in the cartons to cushion them.

- Carton specification

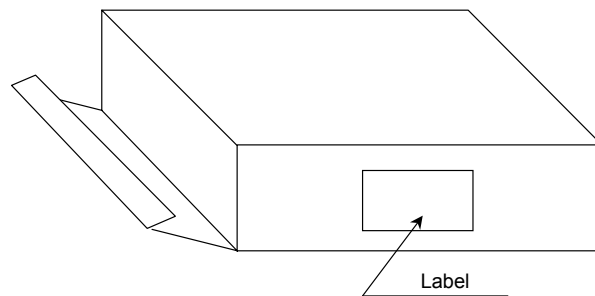

Carton dimensions

(W) 81 mm × (L) 280 mm × (H) 280 mm

Tape Packing Specifications

- (1) Reel dimensions
Reel material: Plastic

Unit: mm

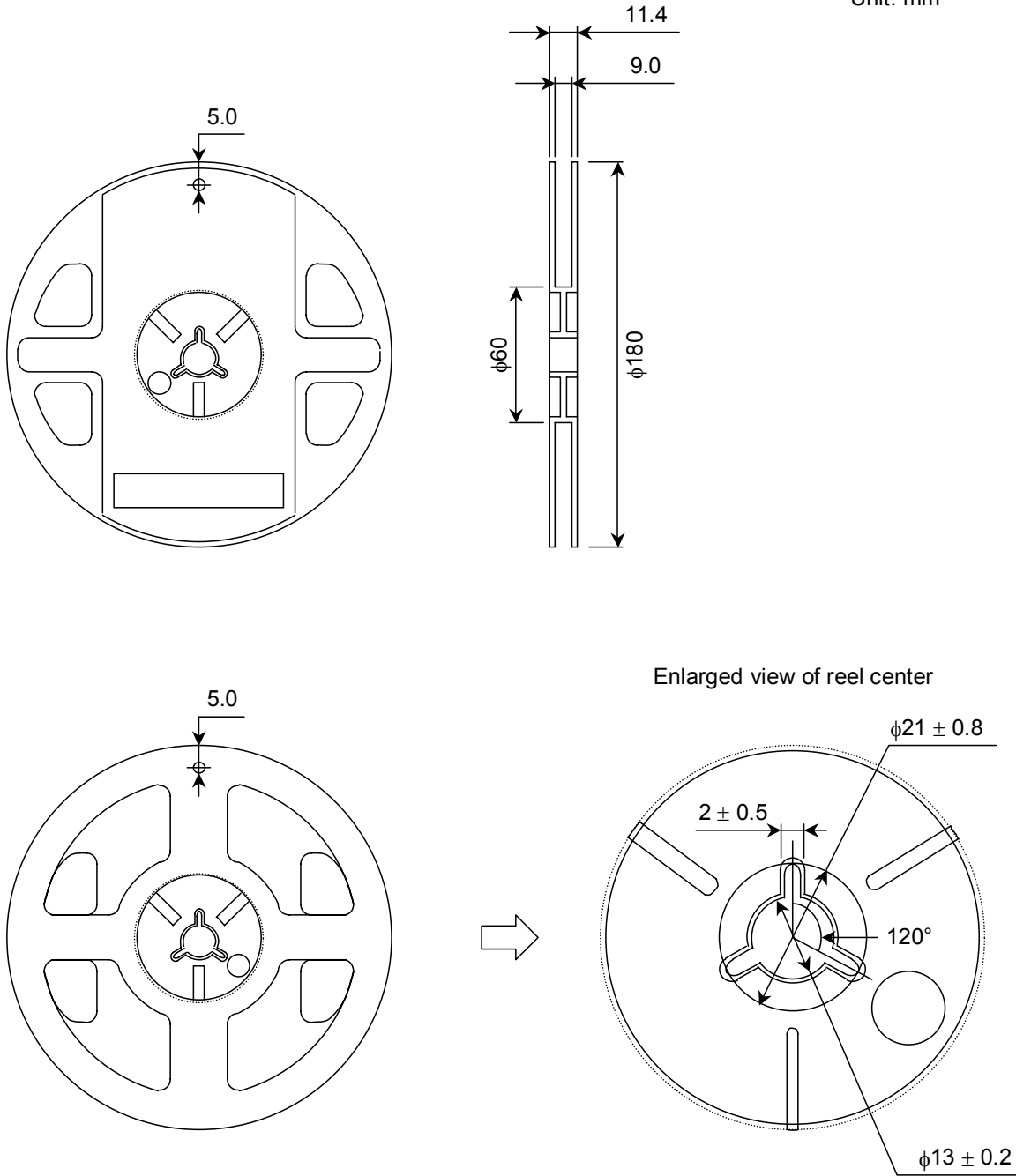

(2) Tape dimensions
Tape material: Plastic (anti-electrostatic)

Unit: mm

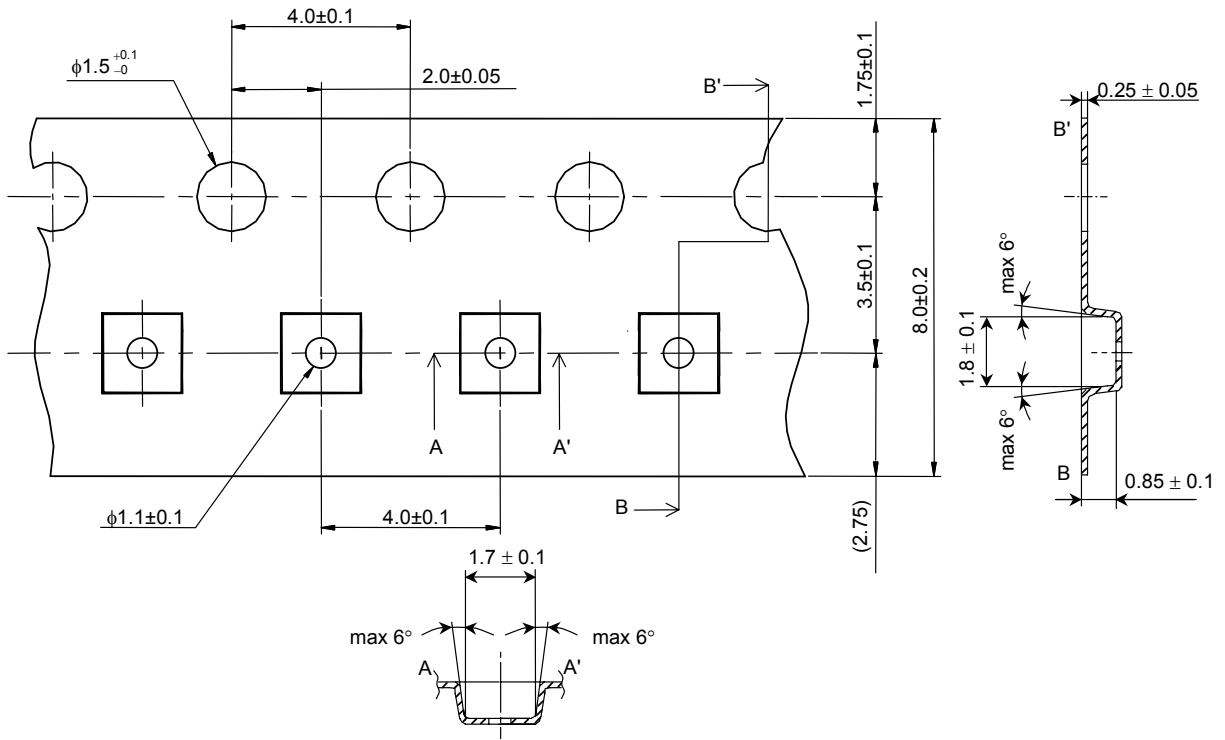

Product direction

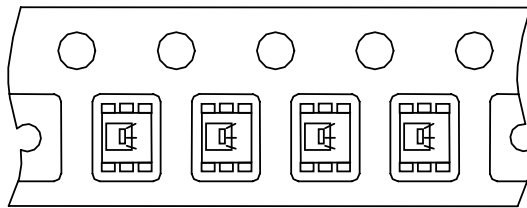

Reel Label

The label markings may include product number, tape type and quantity.

P/N			
TYPE	TPS852		
ADDC		Q'TY	3,000 pcs.
NOTE			

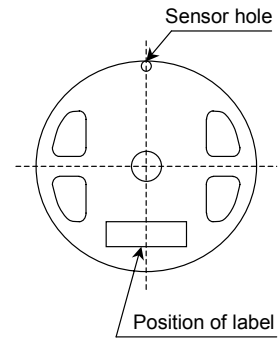

Leader and Trailer Sections of Tape

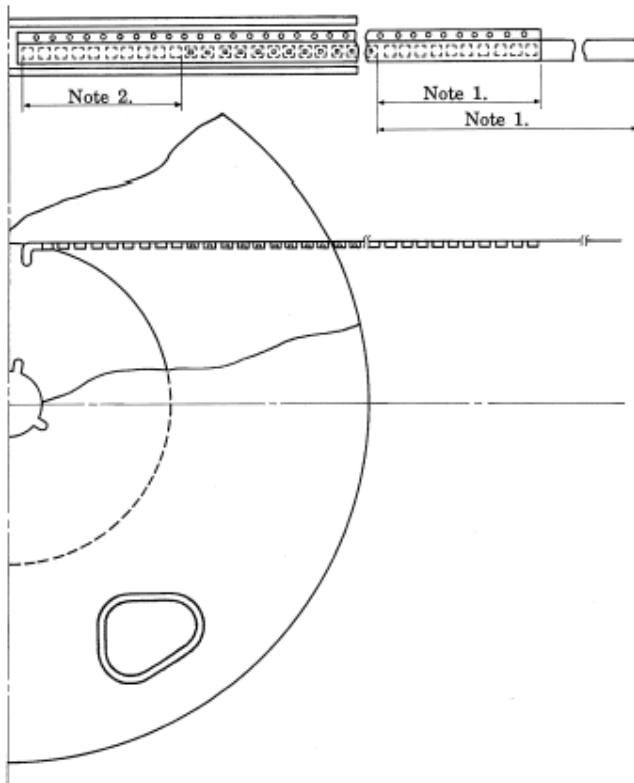

Note 1 : The leader portion shall consist of cover tape minimum length of 300 mm and a piece of carrier tape with empty portion of 100 mm minimum.

Note 2 : The trailer portion shall consist of empty carrier of more than 10 cavities.

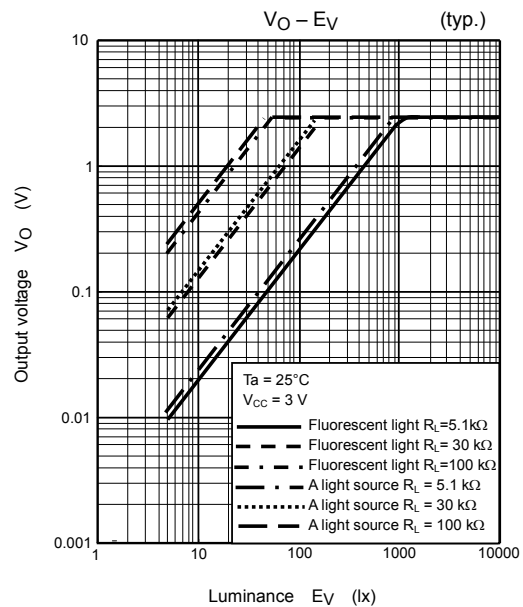
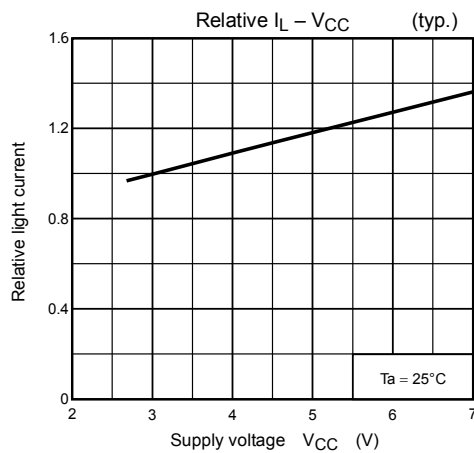
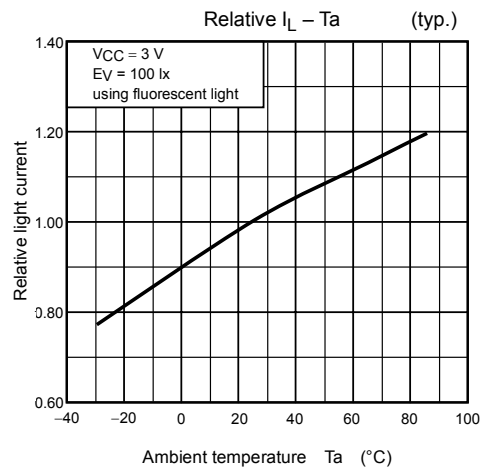
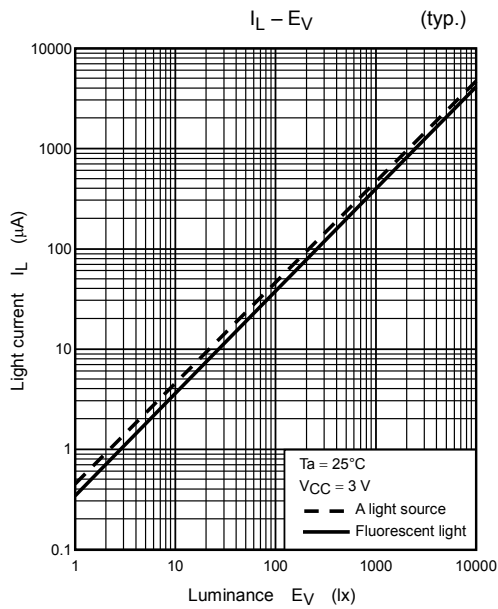
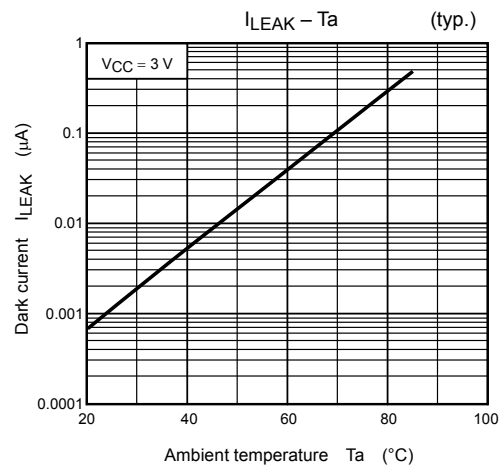
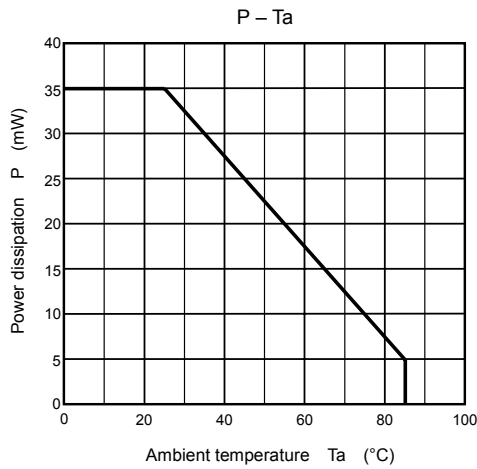

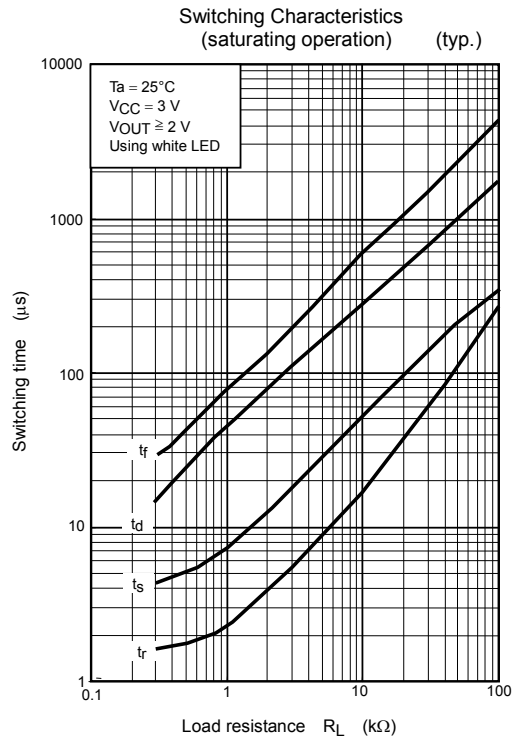
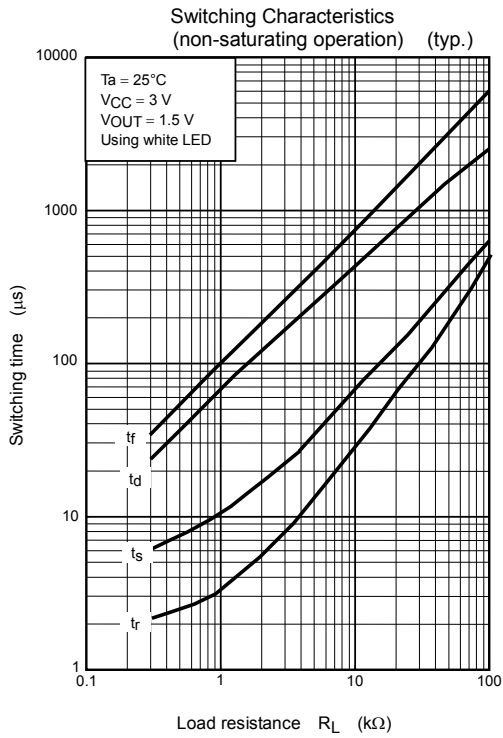
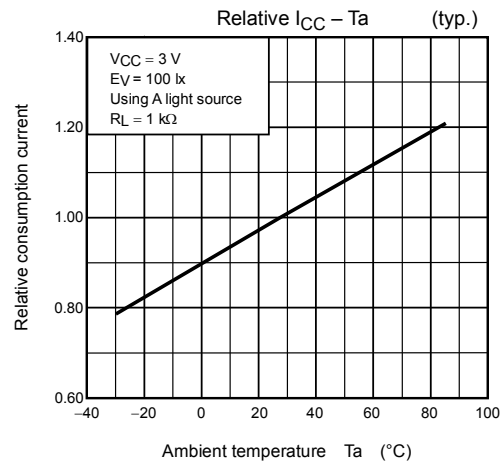
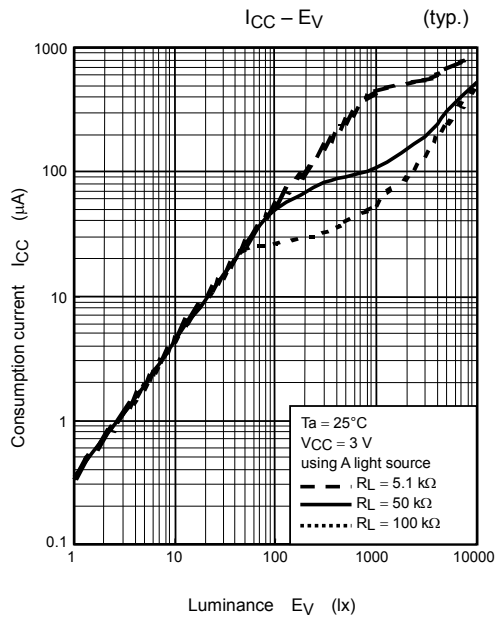

Switching Time Measurement Circuit and Waveforms

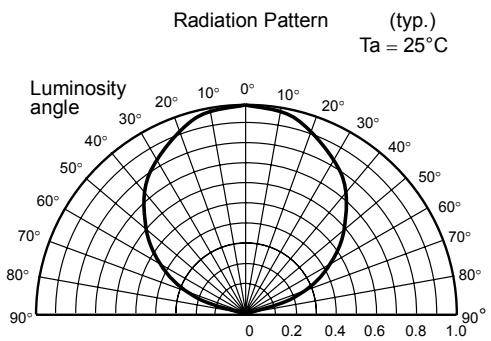
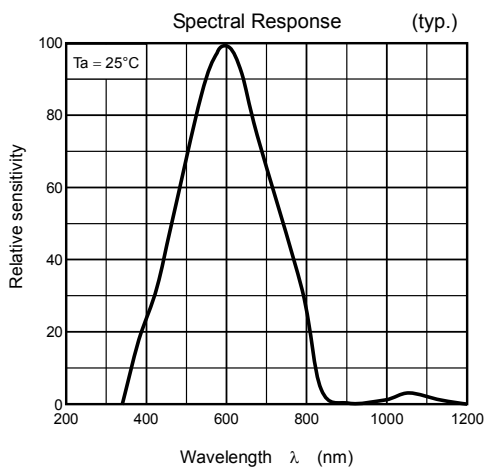
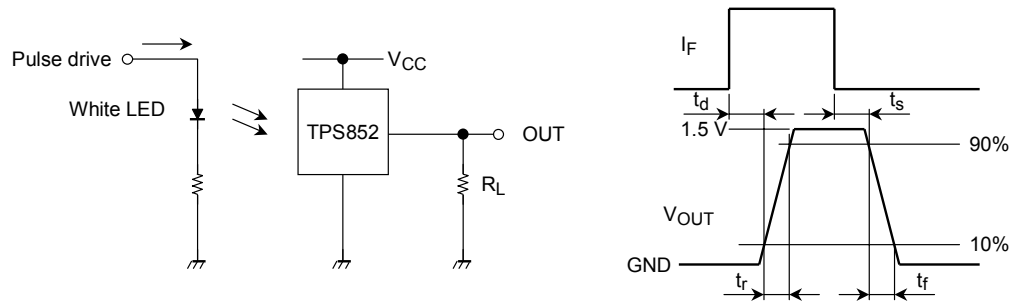

RESTRICTIONS ON PRODUCT USE

030619EBA

- The information contained herein is subject to change without notice.
- The information contained herein is presented only as a guide for the applications of our products. No responsibility is assumed by TOSHIBA for any infringements of patents or other rights of the third parties which may result from its use. No license is granted by implication or otherwise under any patent or patent rights of TOSHIBA or others.
- TOSHIBA is continually working to improve the quality and reliability of its products. Nevertheless, semiconductor devices in general can malfunction or fail due to their inherent electrical sensitivity and vulnerability to physical stress. It is the responsibility of the buyer, when utilizing TOSHIBA products, to comply with the standards of safety in making a safe design for the entire system, and to avoid situations in which a malfunction or failure of such TOSHIBA products could cause loss of human life, bodily injury or damage to property.
In developing your designs, please ensure that TOSHIBA products are used within specified operating ranges as set forth in the most recent TOSHIBA products specifications. Also, please keep in mind the precautions and conditions set forth in the "Handling Guide for Semiconductor Devices," or "TOSHIBA Semiconductor Reliability Handbook" etc..
- The TOSHIBA products listed in this document are intended for usage in general electronics applications (computer, personal equipment, office equipment, measuring equipment, industrial robotics, domestic appliances, etc.). These TOSHIBA products are neither intended nor warranted for usage in equipment that requires extraordinarily high quality and/or reliability or a malfunction or failure of which may cause loss of human life or bodily injury ("Unintended Usage"). Unintended Usage include atomic energy control instruments, airplane or spaceship instruments, transportation instruments, traffic signal instruments, combustion control instruments, medical instruments, all types of safety devices, etc.. Unintended Usage of TOSHIBA products listed in this document shall be made at the customer's own risk.
- The products described in this document are subject to the foreign exchange and foreign trade laws.
- TOSHIBA products should not be embedded to the downstream products which are prohibited to be produced and sold, under any law and regulations.